

**HOW TO USE YOUR  
5000 RANGE  
L.P.G. COOKER  
OR HOB UNIT**



**WARNING: Prior to installation, ensure that the local distribution conditions (nature of the gas and gas pressure) and the adjustment of the appliance are compatible.**

**WARNING:** The adjustment conditions for this appliance are stated on the label (or data plate).

**WARNING:** This appliance is not connected to a combustion products evacuation device. It shall be installed and connected in accordance with current installation regulations. Particular attention shall be given to the relevant requirements regarding ventilation.

**WARNING:** Do not use cooking vessels on the hotplate that overlap its edges of the appliance.

**WARNING:** Do not use the appliance incorrectly. This appliance is designed to be used as a domestic cooking appliance as defined in EN30-1 and must only be used as such.

**WARNING:** This appliance is not intended for use by persons (including children) with reduced physical, sensory or mental capabilities, or lack of experience or knowledge, unless they have been given supervision or instruction concerning the use of the appliance by a person responsible for their safety.

**WARNING:** For marine use, gas regulators should comply with EN 12864 Annex M. Use of inappropriate regulators may invalidate any warranty.

**CAUTION:** These instructions must be read and understood before proceeding with the installation and to avoid any possibility of accident it is essential that the appliances are installed and operated in accordance with these instructions.

**CAUTION:** This unit should be installed according to the current standards in practice in the country of installation.

**CAUTION:** No unit should be installed in a room, van or craft if fixed ventilation is not provided.

**CAUTION:** No alterations or adjustments should be made to the burners or gas supply pressure by unauthorised or unskilled persons. In the event of a failure or breakdown of a unit itself, turn off the gas supply at the cylinder or isolating cock valve for the unit and contact the supplier.

**CAUTION:** Do not remove any parts from the appliance or substitute alternatives as this may affect the performance and safety of the appliance.

**CAUTION:** The installation should be carried out in accordance with the appropriate codes of practice for the country in which the installation is done.

**CAUTION:** If aluminium foil is used in the oven, then it must not be allowed to block the oven flue outlet or smother the burner.

**CAUTION:** Do not spray aerosols in the vicinity of these appliances while they are in operation.

**CAUTION:** This appliance is for cooking purposes only. It must not be used for other purposes such as to heat the vehicle or craft.

**CAUTION:** Turn off the grill once the grill pan has been removed.

**CAUTION:** Be sure appliance taps are closed before opening cylinder valve.

**CAUTION:** Be sure to apply ignition source to burner before opening appliance valve.

**CAUTION:** If you wish to drill the sides for your own gimbals you must first remove the left hand side for drilling as there is a gas pipe behind this panel.

**CAUTION:** When a flexible hose is used do not allow the hose to come into contact with the back panel.

**CAUTION:** Any component used to install this appliance that has a date limit for use, such as flexible hose, must be replaced within the given life of that component.

*Our policy is one of continuous development and for this reason we reserve the right to change the product details and specification without prior notice.*

## INSTALLATION INSTRUCTIONS

This unit should be installed according to the current standards in practice in the country of installation.

|                    |  |
|--------------------|--|
| BS 5482 :          | Part 2 Installations in caravans and non-permanent dwellings<br>Part 3 Installations in boats, yachts and other vessels. |
| EN ISO 10239:2008: | Small craft - Liquid petroleum gas (LPG) systems   |
| BS 6172 :          | Code of practice for installation of domestic gas cooking appliances.  |

THESE APPLIANCES MUST BE INSTALLED BY A COMPETENT PERSON (e.g. a Gas Safe registered fitter)

## VENTILATION

Adequate ventilation must be provided to ensure the cooker unit works in a safe and efficient manner. If fixed ventilation is not provided two ventilation openings of 95 cm<sup>2</sup> must be provided, one near floor level and one near ceiling level. Do not install cookers and hobs in areas subjected to strong draughts.

## INSTALLATION

The unit should only be installed in the countries indicated on the dataplate using the correct gas at the indicated pressure as detailed in figure 1.

This unit must be fixed in place using either the feet or a gimbal system. If using a gimbaling system, ensure the bulkhead is of sufficient strength to hold the weight of the unit and that the gas inlet pipe is free to move with the unit and at no time will become stressed or damaged. See image below for fitting of the gimbal brackets.

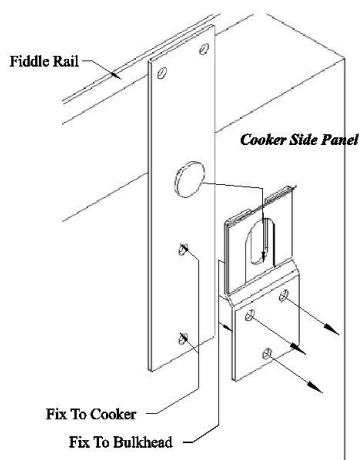

Table 1

| Gas Category      | Gas Type     | Supply Pressure (mbar) | Country of Destination  |
|-------------------|--------------|------------------------|---|
| I <sub>3+</sub>   | G30 □<br>G31 | 28-30 □ 37             | BE, CH, CY, CZ, ES, FR, GB, GR, IE, IT, LT, PT, SI, SK, TR.                             |
| I <sub>3B/P</sub> | G30 □<br>G31 | 30                     | BE, BG, CY, DE, DK, EE, FI, FR, GB, GR, HR, HU, IT, LT, MT, NL, NO, RO, SE, SI, SK, TR. |

An air gap of 40 mm must be allowed at the rear of each cooker and a back stop is fitted to ensure that this gap is maintained. (FIG 3)

There should be no obstruction above the hob burners for a minimum height of 400 mm. (FIG 4). Where cookers are to be fitted into a recess or built in to a unit an air gap of 20 mm must be kept at each side (FIG 4). Use a non-combustable material for the surround such as 0.5 mm sheet steel.

Ensure that no obstruction to the units air flow is permitted at the base, sides or back. Obstruction of the air flow can cause inefficient combustion in the oven.

FIG 3

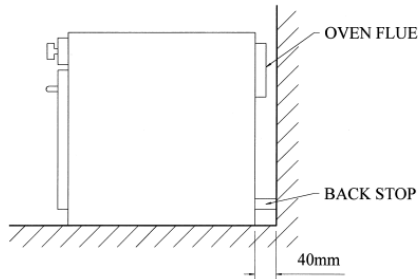
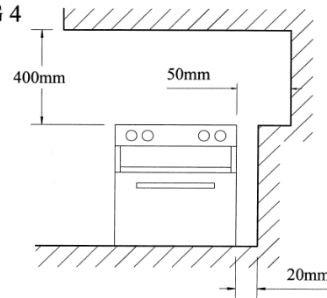

FIG 4



### UNIT DIMENSIONS (FIG 5)

| Measurements | Height (mm) | Width (mm) | Depth (mm) |
|--------------|-------------|------------|------------|
| Neptune      | 570         | 500        | 460        |
| Pacific      | 435         | 500        | 460        |
| Neptune Hob  | 220         | 500        | 420        |

### GAS CONNECTION

These appliances are strictly for use on liquid petroleum gases at the following pressures to the inlet  
 28 mbar (11.2 in w.g.) for Butane (G30)  
 37 mbar (14.8 in w.g.) for Propane (G31)

The gas inlet is located at the rear, top left hand side of the appliance. The gas inlet connection fitting to the appliance should be in accordance with installation requirements according to destination country and gas type as given in EN30-1 table A6. It is recommended that the connecting pipe is, where possible, copper, also that an isolating cock valve is installed in the supply pipe to the unit. For units requiring a flexible pipe a suitable armoured pipe should be used.

Care should be taken during installation to prevent the supply pipe from being held against the back panel of the body.

The unit is supplied with a screw in pressure test nipple. To check the supply pressure, remove one of the hob burner injectors and fit the pressure test nipple and then connect a pressure gauge. The Hob injector **MUST** be replaced after testing.

Once installed the gas connection should be tested for any gas leakage. **DO** ensure the area is well ventilated and **DO NOT** test for a long period; if there is a leak, a build up of gases may occur.

### BURNER ADJUSTMENT AND RATES

All burners are supplied ready for use on BUTANE (G30 @ 28 mbar) / PROPANE (G31 @ 37 mbar). No adjustment of the burners is required.

**Heat Input (model depending) :**

|                       |                   |
|-----------------------|-------------------|
| Semi Rapid Hob Burner | 1.36 kW (99 g/h)  |
| Rapid Hob Burner      | 2.31 kW (168 g/h) |
| Auxiliary Hob Burner  | 1.00 kW (73 g/h)  |
| Grill Burner          | 1.76 kW (128 g/h) |
| Oven                  | 1.38 kW (100 g/h) |

## OPERATING INSTRUCTIONS

MAKE SURE THAT THE GAS IS TURNED ON AT THE CYLINDER. IT IS RECOMMENDED THAT A SPARK IGNITION DEVICE IS USED RATHER THAN A NAKED FLAME.

All burners are fitted with a Flame Failure Safety Shut Off Device (FFD). In the event of the flame being extinguished the gas supply will be cut off to the burner.

The flame should be blue although it may have some yellow tipping. The flame height should be level and stable.

Certain models are fitted with an electronic ignition system. This uses 1 x LR6 (AA) size battery. The battery holder is located at the front underneath the door, on the right hand side. The battery should be checked at regular intervals to ensure their condition. To activate this system push in the button on the front of the fascia marked with a star. The ignition device should not be operated for more than 15 seconds. If after this time the burner has not lit, turn off the gas (and for the oven open the oven door) then wait for at least one minute before attempting further ignition of the burner.

To light a burner push in the appropriate knob, rotate anti-clockwise to the full on position (the large flame symbol (FIG 7), setting 9 for the oven valve) and apply a spark to the burner. It should light immediately, but continue to hold the knob in for a further 15 seconds. If the burner goes out when the knob is released repeat the procedure but hold the knob in for longer before releasing. The tap can then be rotated to the desired setting (high through to low). If any of the burners on the appliance are found to have become extinguished then the valve must be switched off and the unit left for a period of 1 minute to allow any unburned gases to escape, before attempting to re-light the burner. If the oven burner has been extinguished the oven door should be opened as well.

To turn off the gas, rotate the knob clockwise until you reach the off position (the ● symbol vertically above the knob).

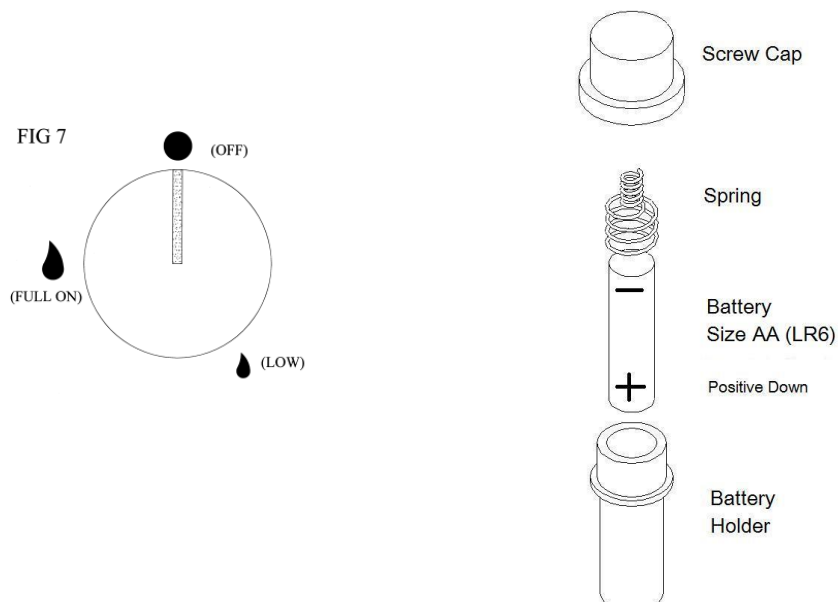

The use of a gas cooking appliance results in the production of heat and moisture in the room in which it is installed. Ensure that the kitchen is well ventilated; keep natural ventilation holes open or install a mechanical ventilation device (mechanical extractor hood). Prolonged intensive use of this appliance may call for additional ventilation, for example the opening of a window, or more effective ventilation, for example increasing the level of mechanical ventilation where present.

## HOBS

Any required setting between full and low/simmer can be obtained by positioning the knob between these two settings. The hob burners are suitable for pan sizes ranging from 10 cm to 22 cm base diameter (4" to 8½").

## GRILL

It is recommended that an oven glove is used when using the grill as the grill pan handle may become hot if the pan is placed too far under the grill. For maximum efficiency place the pan about 30 mm from the front edge of the grill compartment base. It is not necessary to preheat the grill but if a preheat period is used the empty grill pan should be placed under the grill to protect the grill base.

The grill pan trivet is reversible giving a choice of two grilling heights.

## OVEN

The best results will be obtained by pre-heating the oven for about 15/20 minutes at the required gas setting. The tap has 9 marked settings which correspond to the temperature given below. Intermediate temperatures can be obtained by turning the knob to the appropriate setting.

The oven will cook a wide range of food from a rich fruit cake, using a low setting to bread or Yorkshire pudding using the higher settings.

|            |       |
|------------|-------|
| Position 1 | 110°C |
| Position 2 | 130°C |
| Position 3 | 150°C |
| Position 4 | 170°C |
| Position 5 | 190°C |
| Position 6 | 210°C |
| Position 7 | 230°C |
| Position 8 | 250°C |

## COOKER ACCESSORIES (SUPPLIED ACCORDING TO MODEL)

**Pan Support** - The pan support is located in 4 holes on the main hob. The pan support is hooked into the rear holes and then sprung into place at the front edge to prevent rattling.

**Oven Shelf** - To fit an oven shelf, place the shelf so that the hooks are to the back of the cooker, ensuring that they pass under the shelf runners and lift the notches above the runners. If the shelf is correctly fitted it will not tip when pulled forward. (FIG 8)

**Door Catch** - Certain cookers are fitted with a door catch which is fitted to the side of the unit. This will catch the door when closed and the door can then be opened by pushing the catch with a finger or thumb.

**Gimbal Lock** - On models fitted with a gimbal lock below the oven door, a gimbal plate should be fixed to the bulkhead such that when the cooker is locked the hob top is level.

### Baking Tray

### Grill Pan and Trivet

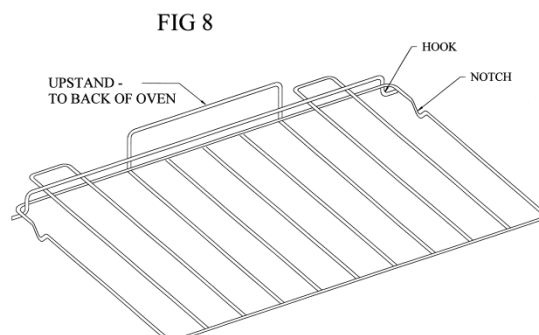

## CLEANING

1. Each time the hob has been used it should be wiped over with a damp cloth and if greasy a little mild liquid cleaner.
2. Stubborn marks can generally be removed with one of the commercial cleaners. Do not use harsh abrasive materials as these will leave scratch marks.
3. The interior of the oven should be cleaned with a damp cloth but if it becomes necessary to use a cleaner then choose an appropriate enamel cleaner.
4. All spillages should be wiped up immediately before they "burn on".

We recommend that you occasionally remove the enameled tops to your burners and clean them ensuring the ports in the top are free from dirt and grease.

If properly adhered to, these few simple suggestions should extend the life of your cooker.

## MAINTENANCE

Before attempting any maintenance work make sure that the gas supply is turned off at the cylinder and disconnected from the unit. If the spillage tray is removed care must be taken to ensure that the gas joints are not stressed as this may result in a gas leak. **NO GAS JOINT SHOULD BE BROKEN.**

The gas valves fitted to this unit are not to be stripped for re-greasing or maintenance purposes. If required, the whole of the valve must be replaced. If any part of the gas system on the appliance needs servicing or replacement this work should be carried out by a competent person (e.g. a Gas Safe registered gas fitter).

**It is recommended that this appliance is professionally serviced at least every 2 years.**

## SPARE PARTS

| Description         | Part No.                 |
|---------------------|--------------------------|
| Oven Thermocouple   | LPS 180-103              |
| Grill Thermocouple  | LPS 181-202              |
| SC Hob Thermocouple | LPS 181-501              |
| Oven Shelf          | LPS 212-201              |
| Pan Support         | 3 Burner Hob LPS 213-201 |
|                     | 2 Burner Hob LPS 213-301 |
| Baking Tray         | LPS 219-101              |
| Grill Pan           | LPS 220-101              |
| Silver Tap Knob     | LPS 252-201              |
| Oven Door Seal      | LPS 237-102              |

More details for spares can be found at [www.marinecooker.co.uk](http://www.marinecooker.co.uk) where you can find photographs to identify the names and part numbers, and also find your nearest spare parts stockist.

If the appliance does not operate correctly  
contact your supplier  
Or

Leisure Products (Bolton) Ltd  
Holly Street, Bolton, BL1 8QR. England.

~~~~~

For further details see also [www.marinecooker.co.uk](http://www.marinecooker.co.uk)